



NRC4792

TVWS based IEEE 802.11ah Wi-Fi Solution + MCU SoC



Overview

As an optimized Wi-Fi solution for internet of things (IoT) devices in the TVWS bands, NRC4792 is the industry's first single system on a chip (SoC) that fully integrates digital baseband modem and RF transceiver. Operating in the UHF TVWS bands, it offers a much greater range over 2.4GHz and 5GHz, even Sub 1GHz technologies. By complying with IEEE 802.11ah standard and supporting 1/2/4MHz channel widths with optional short guard interval (SGI) yield 150 Kbps to 15 Mbps PHY throughput which can support low-rate sensor to high-rate surveillance camera application.



Various power-saving features enable a longer sleep time to greatly reduce power consumption and hence increase battery life. Besides, the capability to obtain surrounding channel information from a geolocation database with the addition of a supplementary spectrum sensing function enables the chip to find the best available channels in an operation site.

The internal power management system provides for the power required inside the chip and therefore allows the chip to operate with a single power input. In addition to this system, the fully integrated RF transceiver simplifies the circuit, minimizes the PCB size, requires minimal external components, and enables fast time-to-market.

The RF transceiver is a complete radio front-end optimized for TVWS band and it has fully integrated pre-power amplifiers as well as the capability to support various commercial external FEM device. NRC4792 can be used either as a standalone device or a slave to a host processor via serial peripheral interface (SPI) or universal asynchronous receiver transmitter (UART) interface. In addition, it can support both AP and STA roles.



Target Applications

- o IoT applications
- o Wearables
- o Home automation
- o Healthcare
- o Industrial automation
- o Safety and security
- o Smart grid
- o Multimedia streaming

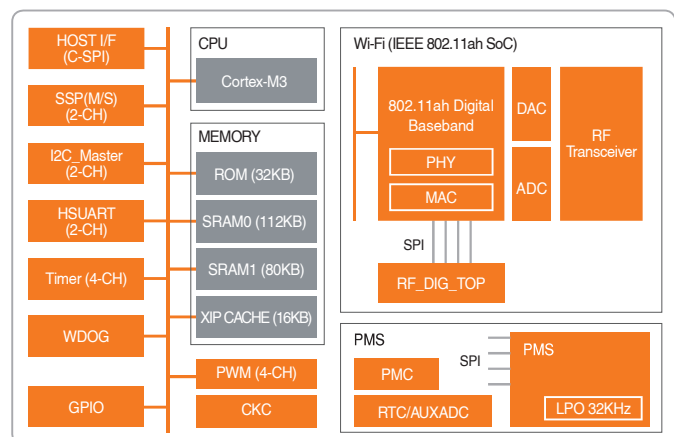



Specification

CPU

- ARM Cortex-M3 for Wi-Fi and application

Memory

- 32KB boot ROM
- 192KB system SRAM
- XIP with cache (1 ways, 16KB)

Communication Peripherals

- Max. 20 GPIOs
- 1x Host SPI for host interface
- 2x SPI master/slave
- 2x HSUART (up to 115200)
- 2x I2C masters
- 4x PWM
- 2x 10-bit ADC

RF Transceiver

- Single-ended RF ports
- Frequency band: 430 to 790MHz
- Linear TX output power: 5dBm
- TX gain range: 30dB
- RX noise figure: <5dB
- Max. input level: -20dBm
- 10bits ADC and 12bits DAC



Key Features

- Complies with IEEE 802.11ah draft 8.0
- Fully Integrated on-chip 11ah modem, RF transceiver, processor, and memory
- Support 1/2/4 MHz bandwidth
- Up to 15 Mbps data rate
- Low power mode operation
 - Legacy
 - WMM-PS
 - TWT
- WPA3 security
- Dedicated SPI and UART interface for host
- Various peripheral interfaces for sensor device
- Manufacturing tools for configuration and test
- Diagnostic and DUT test tools for indoor and outdoor test